

FEATURES

- Triplex plunger pump
- Specifically designed for the agricultural market
- Solid ceramic plungers
- New optimized inlet and outlet valves
- New dual lip oil seal

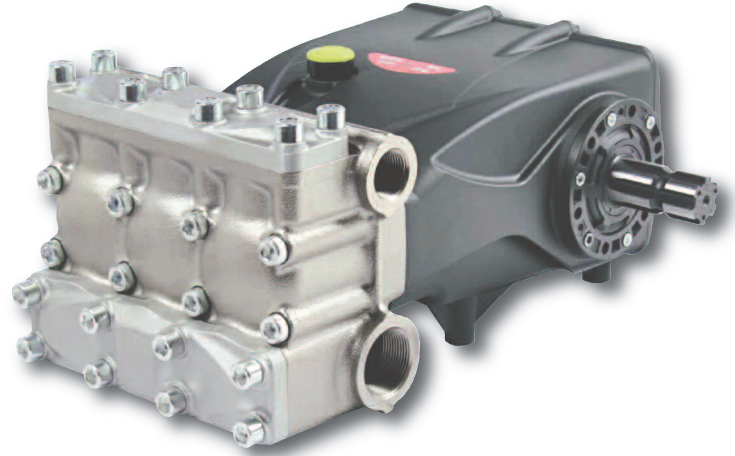

SPECIFICATIONS

Pump Model	AB90	AB120	AB180
Maximum Volume	23.8 GPM	31.7 GPM	47.6 GPM
Maximum Discharge Pressure	870 PSI		
Horsepower	14.0 HP	18.7 HP	28.1 HP
Maximum Pump Speed	650 RPM	550 RPM	650 RPM
Maximum Inlet Pressure	45 PSI		
Plunger Bore	1.42 in. / 36 mm	1.78 in. / 45 mm	1.97 in. / 50 mm
Plunger Stroke	1.78 in. / 45 mm		
Oil Capacity	77.8 oz.		
Inlet Port Thread	1-1/2" BSPP		
Discharge Port Thread	1" BSPP		
Shaft Diameter	1.375 ASAE		
Weight	90.4 lbs.		
Dimensions	17.48" x 17" x 8.29"		

TRIPLEX

TRIPLEX



General Pump
is a member of
the Interpump Group

Ref 300927 Rev.A
04-13



Instructions and Recommendations for the Installation of *AB Series Pumps*

In order to obtain maximum performance in terms of duration of seals and valves, it is necessary to respect a few simple rules, as follows:

- 1) **In order to avoid damage caused by cavitation, the pump must be pressure fed.**

The higher the inlet pressure, the longer the life of the wet end of the pump.

When working at 185°F (85°C), the minimum feed pressure - measured directly in the inlet port of the pump when it is working - is 45 psi (3 bar).

The minimum feed pressure according to the different temperatures are:

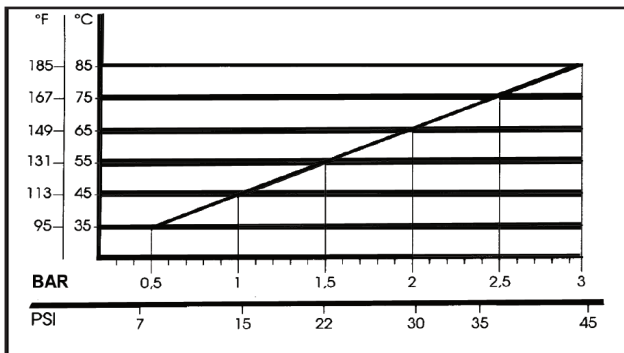

Naturally, if the application allows for feeding the pump with 45 psi (3 bar) even at low temperatures (for example: 115°F/45°C the life of the wet end of the pump will be even longer.

- 2) **The plumbing which feeds the pump must be of a diameter at least equal to the inlet port.**

Also, follow the suggestions below:

- a) Make the plumbing as short and straight as possible, preferably in an upward direction to facilitate the expulsion of eventual air bubbles naturally if compatible with the requirements of the system.
- b) It is always useful to put a filter at the inlet with capacity of 4 to 5 times the flow of

the pump, for example for a 4 gpm (15 l/min) pump, put a filter from 16 to 20 gpm (60-75 l/min). The mesh size suitable for this application is 0.016" (.4 mm).

- c) It is extremely important to put a pressure switch on the suction port of the pump, and in any case downstream from the filter, so that it can stop the pump should the feed pressure drop by 20% due to the filter clogging or failure of the feed pump, etc.

3) Change of oil

We recommend the **first oil change after the first 50 hours**, with the **pump stopped** and the **oil still warm**.

This change is not recommended because the oil has lost its properties, but rather to eliminate the impurities that have gotten into the oil during the running-in phase. If these impurities are not removed, but are allowed to remain in the oil, they *may cause premature wear* to the moving parts and the oil seals. **After this initial change, the oil can then be changed every three months or 300 hours of operation thereafter.**

Please note: If the pump works in conditions with high humidity and with sharp temperature changes, it is possible that condensation will appear inside the crankcase, which mixing with the oil can change its properties. This is easy to see because the oil changes to a white, milky color.

If the pump does not have excessive water leaking from the packings, and the oil becomes milky, the oil has to be changed more frequently. The percentage of water in the oil must not exceed 20%.

Use oil per the following chart:

CHART OF COMPATIBLE OILS SAE15W40	
General Pump	Series 100
BP	VISCO 2000
CASTROL	CWX
MOBIL	SUPER
SHELL	HELIX SUPER
TOTAL	QUARTZ 4000-5000

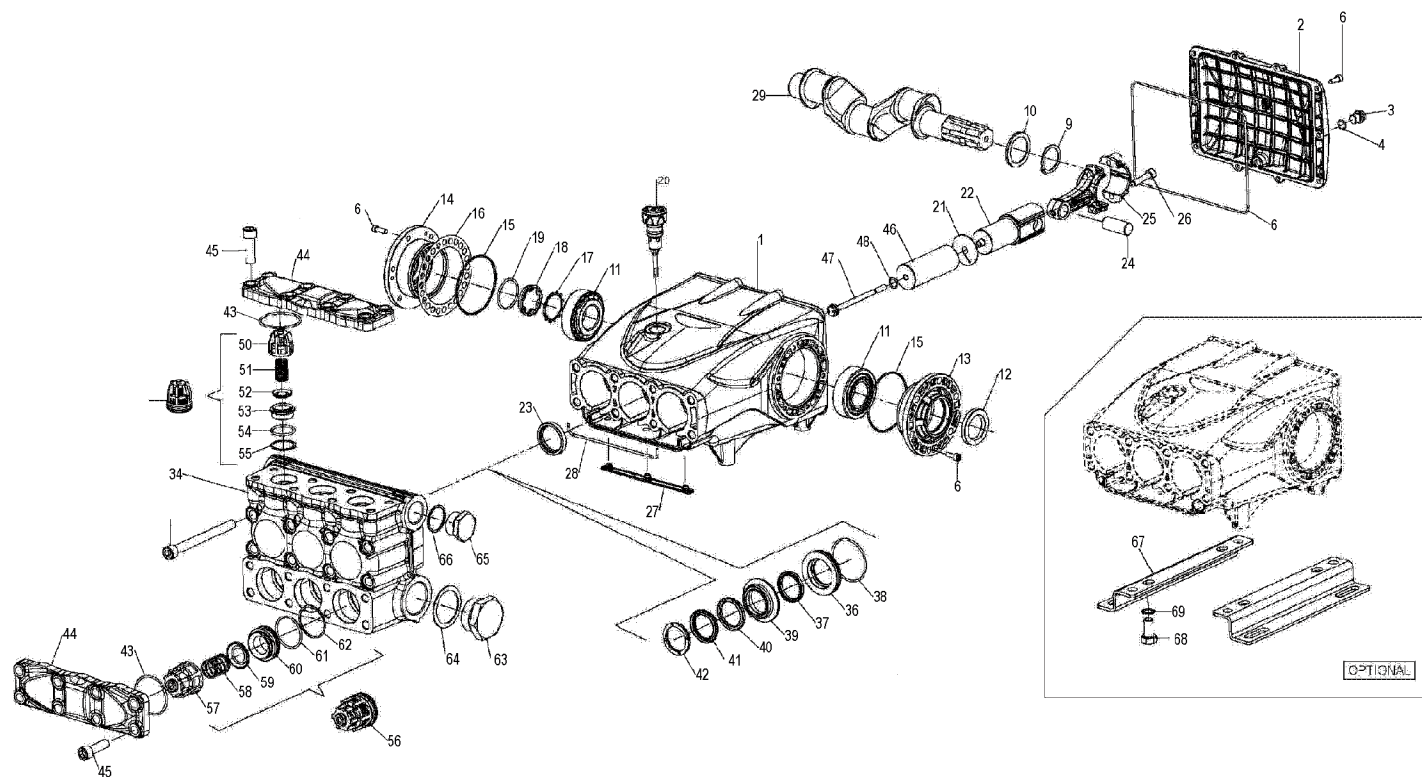

PARTS LIST

ITEM	PART NO.	DESCRIPTION	QTY	ITEM	PART NO.	DESCRIPTION	QTY	ITEM	PART NO.	DESCRIPTION	QTY
1.	68010022	Crankcase	1	29.	68020135	Crankshaft, 1-3/8 ASAE	1	46.	71040409	Plunger, 36x95 (AB90)	3
2.	68160022	Rear Cover	1	34.	68120013	Manifold, Ø36	1		68040009	Plunger, 45x95 (AB120)	3
3.	98204250	Plug, G1/4"x12	1		68120213	Manifold, Ø45	1		68040109	Plunger, 50x95 (AB180)	3
4.	90358500	O-ring, Ø10.82x1.78	1		68120313	Manifold, Ø50	1	47.	71219566	Plunger Screw	3
5.	90395000	O-ring, Ø215.57x2.62	1	35.	99446600	Screw, M12x130	8	48.	90367100	O-ring, Ø11x2	3
6.	99185400	Screw, M6x16	22	36.	68080070	Packing Retainer, Ø36	3	49.	36720601	Valve, Outlet	3
9.	90069500	Snap Ring	1 or 2		68080270	Packing Retainer, Ø45	3	50.	36200951	Valve Cage	3
10.	68210554	Spacer, Bearing	1 or 2		68080370	Packing Retainer, Ø50	3	51.	94745000	Spring, 16x27.5	3
11.	91847300	Roller Bearing	2	37.	90279800	Packing, Ø36, LP	3	52.	36201076	Valve Plate	3
12.	90167200	Oil Seal, 35x52x7	1 or 2		90284600	Packing, Ø45, LP	3	53.	36204866	Valve Seat	3
13.	70150022	Side Cover	1 or 2		90286000	Packing, Ø50, LP	3	54.	90386500	O-ring, Ø29.82x2.62	3
14.	70150122	Side Cover, PTO	1	38.	90390000	O-ring, Ø58.42x2.62	3	55.	90517800	Anti-ext Ring	3
15.	90391500	O-ring, Ø80.6x2.62	2		90390700	O-ring, Ø63.17x2.62	3	56.	36720501	Inlet Valve Assembly	3
16.	70220081	Shim, 0.1mm		39.	68210070	Intermediate Ring, Ø36	3	57.	36204551	Inlet Valve Guide	3
	70220381	Shim, 0.25mm			68210270	Intermediate Ring, Ø45	3	58.	94754100	Spring, Ø24.7x31	3
17.	90075600	Restop Ring	1		68210370	Intermediate Ring, Ø50	3	59.	36211576	Valve Plate	3
18.	70211801	Oil Sight Glass	1	40.	90286500	Restop Ring, Ø50x65x8/4.5	3	60.	36211666	Inlet Valve Seat	3
19.	90387700	O-ring, Ø39.34x2.62	1		90281800	Restop Ring, Ø36x48x6/3	3	61.	90388000	O-ring, Ø42.52x2.62	3
20.	98211500	Oil Dipstick	1		90284800	Restop Ring, Ø45x60x6.3/3	3	62.	90523300	Anti-ext. Ring	3
21.	96709900	Washer, Ø10x45x1	3	41.	9028200	Packing, Ø36x48x6/3.5, HP	3	63.	98244100	Cao, G1-1/2"x20	1
22.	98050022	Plunger Guide	3		90286300	Packing, Ø50x65x7.5/4.5, HP	3	64.	96802000	Washer, Ø48x60x1.5	1
23.	90167600	Ring, Rad. Ø36x47x7	3		90285000	Packing, Ø45x60x7.5, HP	3	65.	98232500	Cap, G1"x17	1
24.	97742500	Pin, Ø18x45	3	42.	71100251	Head Ring, Ø36	3	66.	96787000	Washer, Ø33.5x38x1.5	1
25.	68030001	Connecting Rod Assembly	3		68100051	Head Ring, Ø50	3	67.	76200074	Pump Foot	2
26.	90309900	Connecting Rod Screw	3		76100251	Head Ring, Ø45	3	68.	99426600	Screw, M12x25	4
27.	68210651	Protector	1	43.	90389300	O-ring, Ø53.65x2.62	6	69.	96719500	Washer, Ø13x18x1.1	4
28.	68210782	Sponge, Guaranty		44.	68210422	Valve Cover	2				
				45.	99430500	Screw, M12x40	16				

REPAIR KITS

Kit No.	K295	K296	K297	K298	Ø36 (AB90)	Ø45 (AB120)	Ø50 (AB180)
					K299	K301	K302
Item Nos. Included In Kit	43, 50, 51, 52, 53, 54, 55 (49)	43, 57, 58, 59, 60, 61, 62 (56)	33	12	37, 38, 40, 41, 42	37, 38, 40, 41, 42	37, 38, 40, 41, 42
Number of Assy's In Kit	3	3	3	2	3	3	3
Number of Cylinders Kit Services	-	-	3	NA	3	3	3

TORQUE SPECS*

Position	Ft.-Lbs.	Nm.
3	14.8	20
6	7.4	10
26	14.8	20
35	59	80
45	59	80
47	14.8	20
63	110.6	150
65	88.5	120
68	59	80

*Decrease torque by 20% if threads are lubricated.
**Use Loctite 542 Red

DIMENSIONS

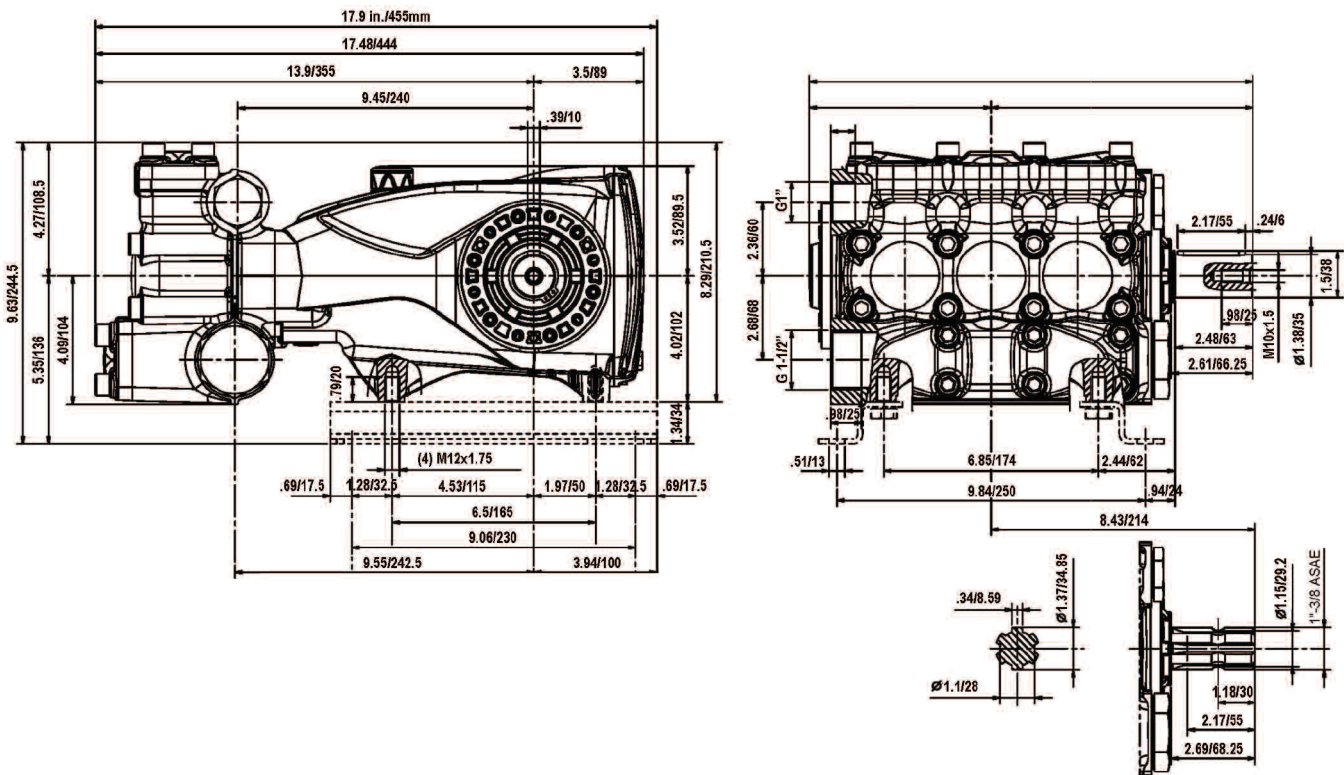

Ref 300927 Rev.A
04-13

