

T Series 76

30 mm bore – Triplex Plunger Pump

FEATURES

- The industry's choice for high-flow applications
- Forged brass manifold with an exclusive lifetime warranty
- Large-capacity, die-cast, anodized aluminum oil-bath crankcase
- Over-sized connecting rods for maximum life
- Heavy-duty tapered roller bearing.
- Solid ceramic plungers with continuously lubricated packings
- Unitized stainless steel inlet and discharge valves



SPECIFICATIONS

Pump Model	T1551
Maximum Volume	14.0 GPM
Maximum Discharge Pressure	2175 PSI
Maximum Pump Speed	1000 RPM
Maximum Inlet Pressure	125 PSI
Maximum Inlet Vacuum	9 ft. water (7.9 in. Hg)
Bore	1.181 in. / 30 mm
Stroke	1.102 in. / 28 mm
Crankcase Oil Capacity	91 oz.
Maximum Fluid Temperature	165°F
Inlet Port Thread	1-11 BSPP-F
Discharge Port Thread	3/4-14 BSPP-F
Shaft Diameter.	1.378 in. / 35 mm
Weight	93 lbs.
Dimensions	15.6 x 14.0 x 9.5 in.

DIMENSIONAL DRAWING

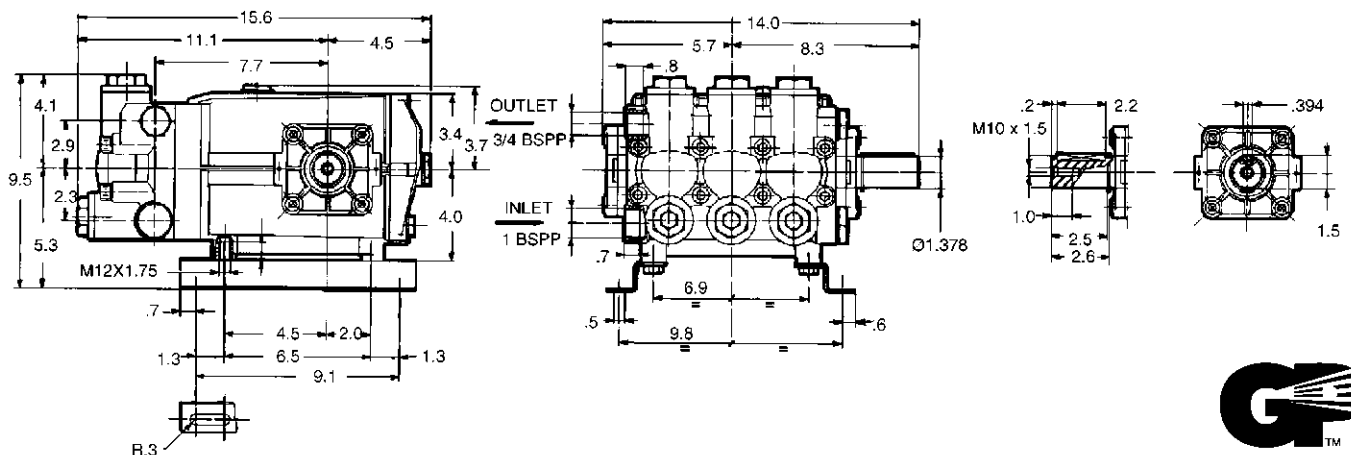

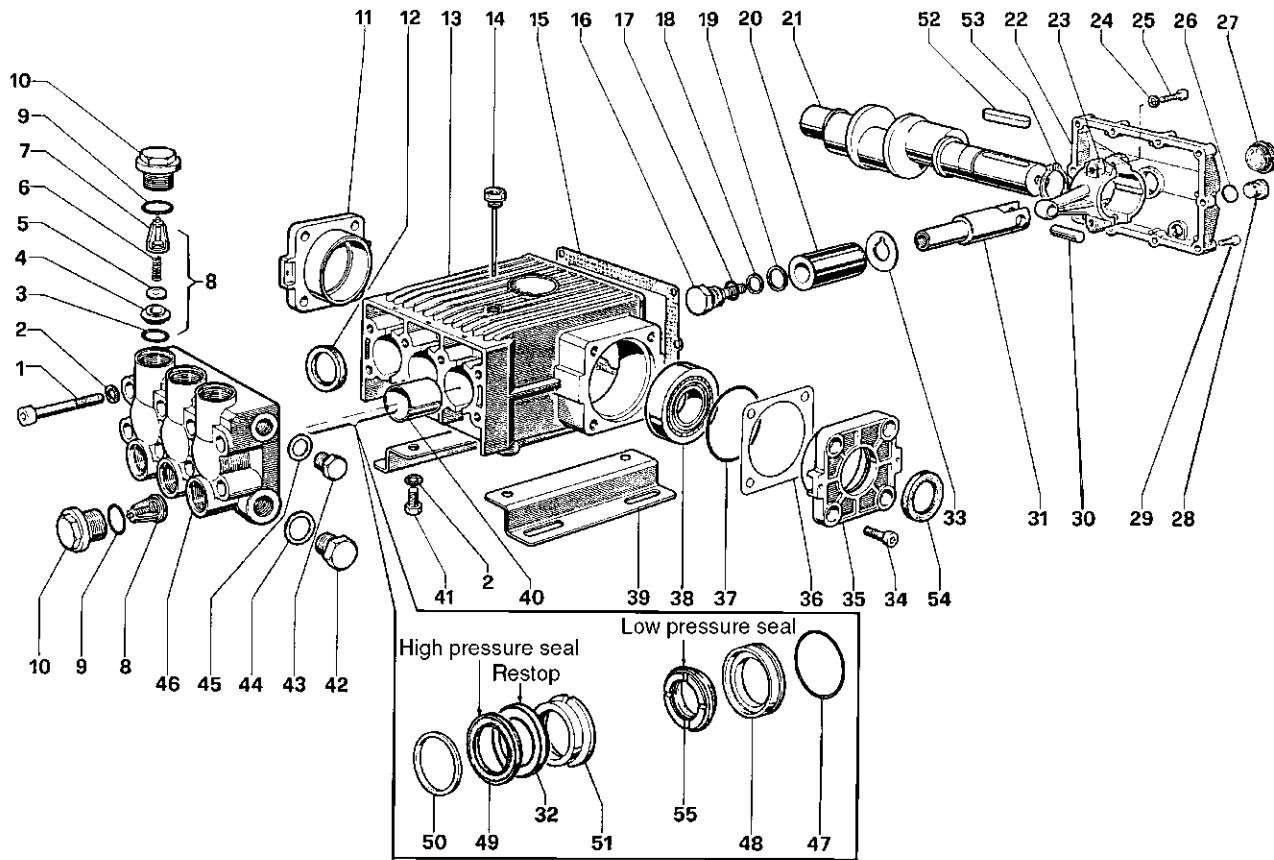

PARTS LIST

ITEM PART NO.	DESCRIPTION	KIT NO.	QTY.	ITEM PART NO.	DESCRIPTION	KIT NO.	QTY.	ITEM PART NO.	DESCRIPTION	KIT NO.	QTY.	
1	99.4418.00	Screw	8	19	96.7555.00	Washer	74	3	37	90.4141.00	O-Ring	2
2	96.7195.00	Washer	12	20	76.0400.56	Plunger (30 mm)	3	38	91.8474.00	Bearing	2	
3	90.4059.00	O-Ring	43	21	76.0210.35	Crankshaft	1	39	76.2000.74	Bar	2	
4	36.2011.66	Valve Seat	43	22	76.1600.22	Cover	1	40	90.9172.00	Bushing	6	
5	36.2010.76	Valve	43	23	76.0303.01	Connecting Rod	3	41	99.4266.00	Screw	4	
6	94.7450.00	Spring	43	24	96.7104.00	Washer	6	42	98.2325.00	Cap	1	
7	36.2009.51	Valve Guide	43	25	99.3720.00	Screw	6	43	98.2265.00	Cap	1	
8	36.7065.01	Valve Unit	43	26	90.3833.00	O-Ring	2	44	96.7870.00	Washer	1	
9	90.4065.00	O-Ring	6	27	97.5968.00	Oil Indicator	1	45	96.7700.00	Washer	1	
10	98.2420.00	Cap	6	28	98.2100.00	Cap	2	46	76.1210.41	Manifold	1	
11	76.1501.22	Cover	1	29	99.1897.00	Screw	10	47	90.3903.00	O-Ring	114, 115	3
12	90.1670.00	Ring	44	30	97.7400.00	Plunger Pin	3	48	76.0800.70	Packing Retainer	114, 115	3
13	76.0102.01	Crankcase	1	31	77.0500.54	Plunger Guide	3	49	90.2770.00	Packing	113, 115	3
14	98.2270.00	Oil Dip Stick	1	32	90.2774.00	Ring	113, 115	50	69.1000.51	Head Ring	65, 115	3
15	76.2119.84	Gasket	1	33	96.7568.00	Washer	3	51	69.2167.70	Intermed. Ring	66, 115	3
16	69.2195.66	Plunger Screw	74	34	99.3652.00	Screw	8	52	91.4978.00	Key		1
17	90.3841.00	O-Ring	74	35	76.1500.22	Cover	1	53	90.0695.00	Clip		1
18	90.5107.00	Anti-Ext. Ring	74	36	76.2200.78	Shim	2	54	90.1672.00	Seal	32	1
								55	90.2776.00	Seal, Low Press., 30mm	113, 115	3

REPAIR KITS

KIT NO.	32	43	44	65	66	74	113	114	115
ITEM NO.s INCLUDED IN KIT	54	3, 4, 5, 6, 7 (8)	12	50	51	16, 17, 18, 19	32, 49, 55	47, 48	32, 47, 48, 49, 50, 51, 55
NUMBER OF ASSEMBLIES IN KIT	2	6	3	6	3	3	3	3	1
NUMBER OF CYLINDERS KIT WILL SERVICE	-	6	3	3	3	3	3	3	1

TORQUE SPECS*

Position	Ft.-lbs.
1	51.5
10	95.8
16	29.4
25	29.4
27	13.2
28	29.4
29	7.3
34	29.4
41	51.5
42	73.7
43	51.5

*Decrease torque by 20% if threads are lubricated.

