

FEATURES

- Forged brass manifold with exclusive lifetime warranty
- High flow applications
- Dual manifolds utilizing a common crankcase for efficient performance
- Solid ceramic plungers with continuously lubricated packings
- Unitized stainless steel inlet and discharge valves

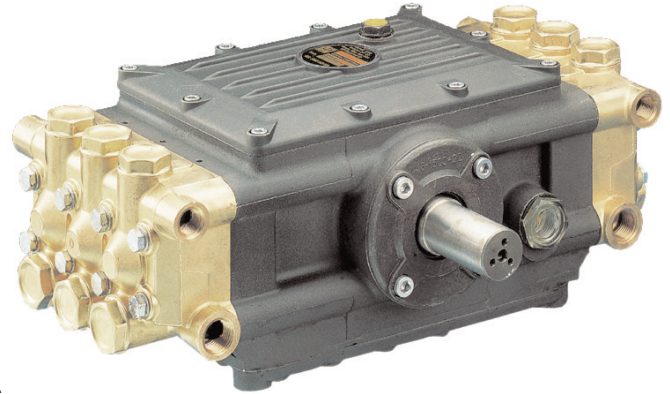

SPECIFICATIONS

Pump Model	TS1351 *	T1631	T2031	
Maximum Volume (GPM)	11.0 GPM	10.0 GPM	9.0	11.0
Max. Discharge Pressure (PSI)	2000 PSI	2500 PSI	3000	2000
Maximum Pump Speed (RPM)	1450	1080 RPM	1140	1450
Maximum Inlet Pressure		125 PSI		
Maximum Inlet Vacuum		9 ft. water (7.9 in. Hg)		
Bore (in./mm)	.787 / 20	.866 / 22	.787 / 20	
Stroke		.630 in. / 16 mm		
Crankcase Oil Capacity		54.0 oz.		
Maximum Fluid Temperature		165°F		
Inlet Port Thread		3/4-14 BSPP-F		
Discharge Port Thread		3/8-19 BSPP-F		
Shaft Diameter.		1.26 in. / 32 mm		
Weight		61 lbs.		
Dimensions		16.1 x 11.2 x 7.9 in.		

*Out of production; use T2031.

DIMENSIONAL DRAWING

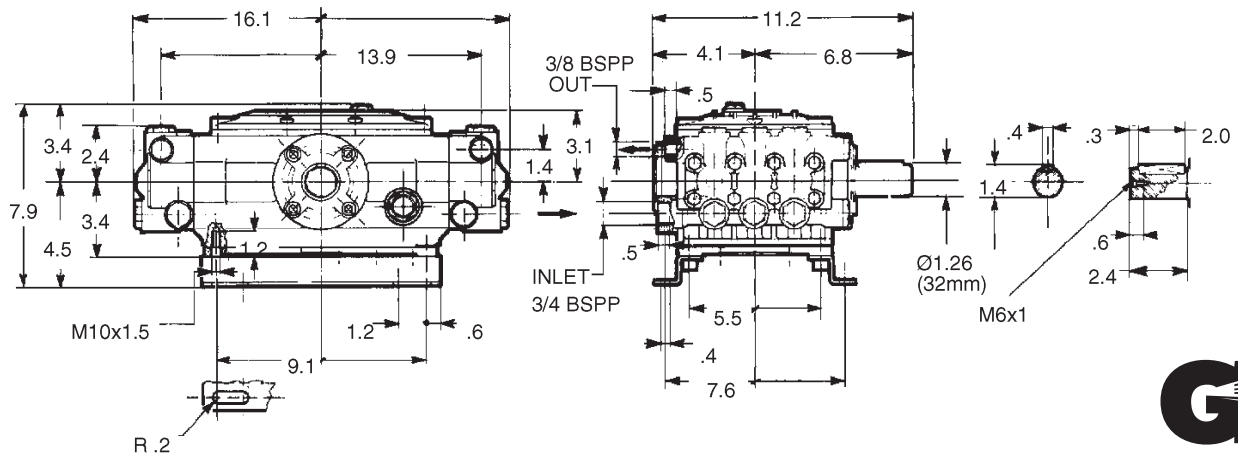

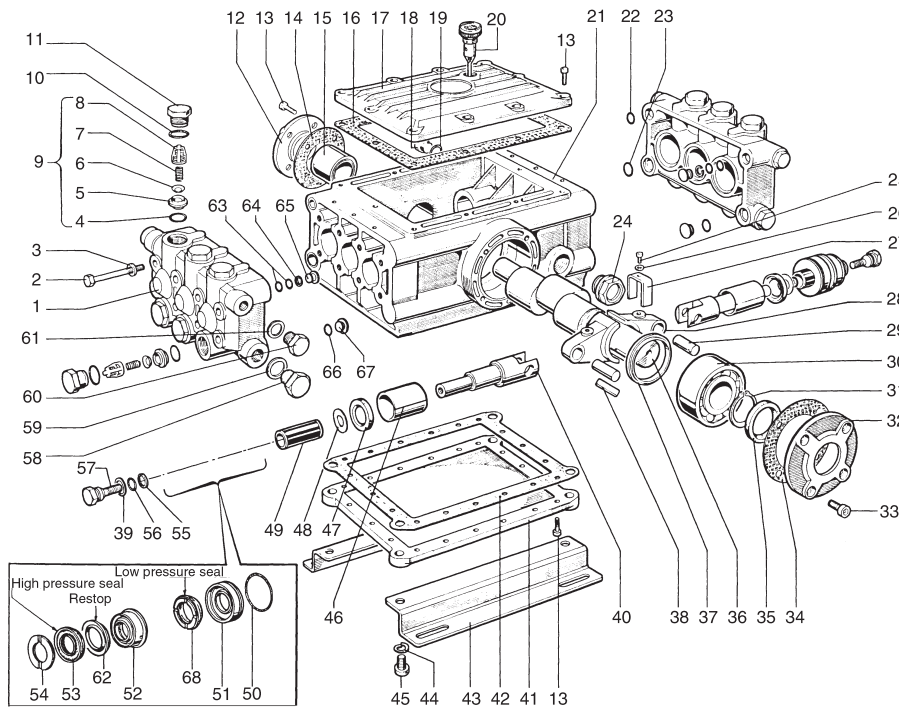

PARTS LIST

ITEM	PART NO.	DESCRIPTION	KIT NO.	QTY.	ITEM	PART NO.	DESCRIPTION	KIT NO.	QTY.	ITEM	PART NO.	DESCRIPTION	KIT NO.	QTY.
1.	48120241	Manifold		2	26.	96691000	Washer		6	50.	90361600	O-Ring	10,14,28,29	6
2.	99320600	Screw		16	27.	48217074	Rod Yoke		6	51.	47080570	Packing Retainer	10, 28	6
3.	96702000	Washer		16	28.	48030122	Connect. Rod		3		47080670	Pack. Ret. (T1631)	14, 29	
4.	90384100	O-Ring	1	12	29.	97737400	Plunger Pin		6	52.	47216970	Intermed. Ring	28, 71	6
5.	36200366	Valve Seat	1	12	30.	91847500	Bearing		1		47217070	Inter. Ring (T1631)	29,149	
6.	36200176	Valve	1	12	31.	90069500	Cir-Clip		1	53.	90270500	Packing	28, 69	6
7.	94737600	Spring	1	12	32.	48150022	Cover		1		90272500	Packing (T1631)	29, 148	
8.	36200251	Valve Guide	1	12	33.	99303900	Screw		4	54.	47100051	Head Ring	7, 28	6
9.	36703201	Valve Unit	1	12	34.	48211284	Gasket		1		46100051	Head Ring (T1631)	11, 29	
10.	90384700	O-Ring	4	12	35.	90167000	O-Ring		1	55.	90506700	Anti-Ext. Ring	6	6
11.	98222000	Cap	4	12	36.	48020135	Crankshaft		1	56.	90358500	O-Ring	6	6
12.	48160122	Cover	1	1	37.	48212389	Connect Rod Ring		6	57.	47219566	Plunger Screw	6	6
13.	99183700	Screw		32	38.	91497500	Key		1	58.	98217600	Cap	4	4
14.	48211984	Cover Gasket		1	39.	96728000	Washer	6	6	59.	96751400	Washer	4	4
15.	91837000	Bearing		1	40.	48050154	Plunger Guide		6	60.	98210000	Cap	3	3
16.	48211884	Gasket		1	41.	48211622	Cover		1	61.	96738000	Washer	3	3
17.	48211422	Cover		1	42.	48211784	Gasket		1	62.	90270400	Restop Ring	28,69,71	6
18.	98204100	Cap		1	43.	48200074	Foot		2		90273000	Res. Ring (T1631)	29,148,149	
19.	90358500	O-Ring		1	44.	96710600	Washer		4	63.	90358000	O-Ring	4	4
20.	98209700	Cap		1	45.	99369900	Screw		4	64.	90503700	Anti. Ext. Ring	2	2
21.	48010402	Crankcase		1	46.	90915000	Bushing		6	65.	48220470	Plug	2	2
22.	90382700	O-Ring		4	47.	90162700	Ring	24	6	66.	90382500	O-Ring	2	2
23.	90383900	O-Ring		4	48.	96728600	Washer		6	67.	48220370	Plug	2	2
24.	97596800	Oil Indicator		1	49.	47040409	Plunger – 20 mm		6	68.	90271000	Seal, Low Press., 20mm	28, 69	6
25.	99153700	Screw		6		47040509	Plunger – 22 mm (T1631)							

REPAIR KITS

KIT NO.	1	4	6	7 (20mm) 11 (22mm)	10 (20mm) 14 (22mm)	24	28 (20mm) 29 (22mm)	69 (20mm) 148 (22mm)	71 (20mm) 149 (22mm)
ITEM NO.s INCLUDED IN KIT	4, 5, 6, 7, 8 (9)	10, 11	39, 48, 55, 56, 57	54	50, 51	47	50, 51, 52, 53, 54, 62, 68	53, 62, 68	52, 62
NUMBER OF ASSEMBLIES IN KIT	6	6	3	6	3	3	1	3	3
NUMBER OF CYLINDERS KIT WILL	3	3	3	3	3	3	1	3	3

TORQUE SPECS*

Position	Ft.-lbs.
2	22.1
11	73.7
13	7.3
18	14.7
24	13.2
25	5.1
33	14.7
45	29.4
57	14.7
58	29.4
60	29.4

*Decrease torque by 20% if threads are lubricated.